

PRODUCTSPECIFICATION

Art. name: NLP Plastic crate 185

Art. number: 0102

EPD number: 2630739

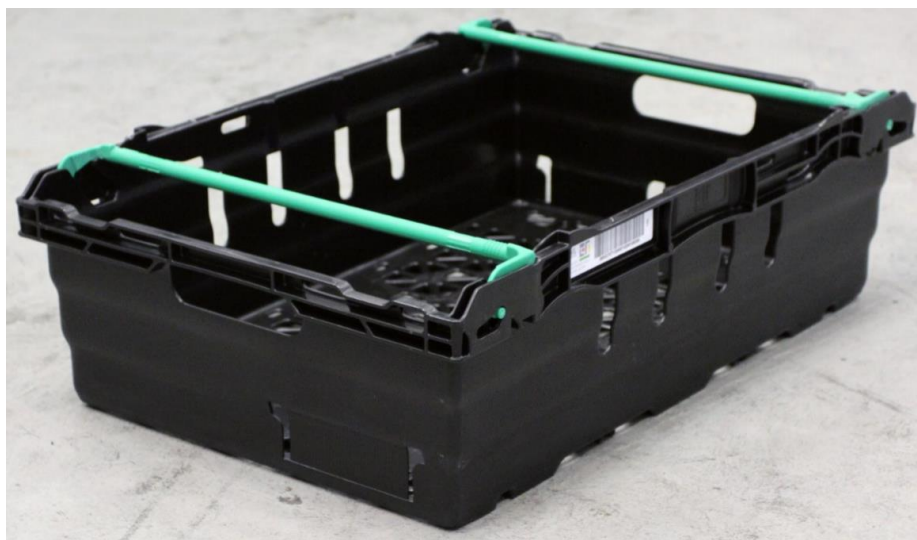

PRODUCT DESCRIPTION

Dimensions	Outside (mm) +/- 2%	Inside bottom +/- 2%	Working height high bar +/- 2%	Working height low bar +/- 2%
Length (mm)	600	546		
Width (mm)	400	348		
Height (mm)	185		160	130
Volume			32 liters	26 liters

Weight complete crate	1,650 Kg. +/- 5 %
------------------------------	-------------------

Materials crate	Food Grade High Impact Polypropylen.
Materials bar	Polyamid (PA6) with 50% glassfiber.
Recycled materials	Recycled raw material of Food Grade high Impact Polypropylen can be mixed in.

Kapittel: 0303	Dok nr: 03 Vers nr: 04	Gyldig fra: 27.08.20	Utarbeidet av: SMSS	Revidert av: SMSS	Godkjent av: FH	Side 1 av 3
----------------	---------------------------	-------------------------	------------------------	----------------------	-----------------	-------------

NEST STACK

Nest stacking system	2 swing bars
Incremental stack height (High)	173 mm (+/- 2%)
Incremental stack height (Low)	144 mm (+/- 2%)
Incremental nest height	43 mm (+/- 2%)
Maximum load per single tray (excl. tray weight)	Maximum recommended content weight per single tray (high stack position): 18,0 Kg. Maximum recommended content weight per single tray (low stack position): 13,0 Kg.
Maximum stack load	Maximum load on bottom tray = 182 Kg. Dynamic
Loading note	Dynamic load rating depends on the use of restraining methods on pallets, how they are secured inside transportation units as well as the general handling of the crate.
Temperature performance	-30 °C to +40 °C All stated loadings are assumed static at an operational temperature of +21 °C +/- 2 °C for 7 days. However, it should be noted that the load bearing capabilities of Polypropylen improves at reduced temperatures and are lowered at elevated temperatures. Conversely, as with all plastic materials, impact resistance is reduced at low temperatures and is increased at higher temperatures.

RFID AND BARCODE

The crate is equipped with two RFID tags and barcode labels. RFID- and barcode labels is placed on the outer edge of the two longer sides. Please see picture for placement.
More information about RFID and barcodes can be found at our website www.nlpool.no



LABELING THE CRATES

The crates have label holders on each of the short sides, with room for labels without glue in size 130x45 mm

Using labels with glue the, following suppliers, label type and glue are approved:

Supplier	Type of label and glue
Raflatac	Thermal Top 200 / RP-45LW
Raflatac	Thermal Top P 200 / RP45LW
Fasson	Vellum Extra / WR 3000

Placement of labels

Labels with glue shall **only** be placed at the designated areas, see drawing below. It illustrates by measures in mm where the label is placed from the edge and bottom. The label can be a **maximum** of 50 mm in height.

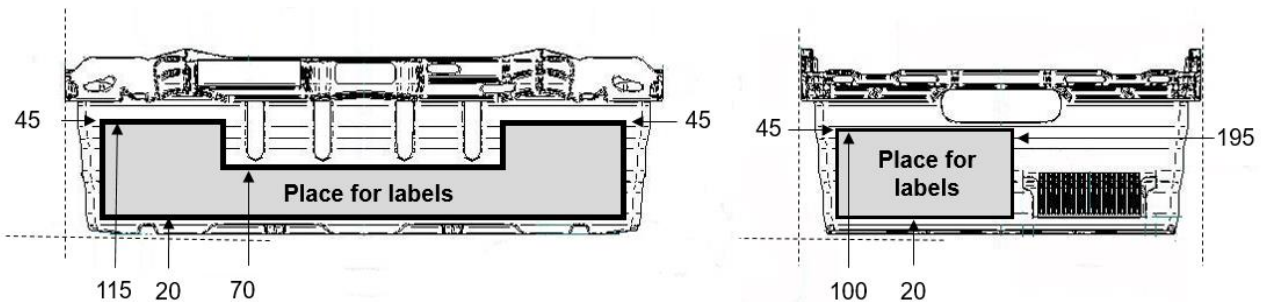

WASHING OF CRATES

Crates are washed in a tunnel washer designed for crates, where foreign substances and the remains of old labels are removed to the best of our ability.

The crate and bars shall remain whole and the crate shall have no visible contaminations. Deviations up to a diameter of 30 mm may occur.

DELIVERY

The crates are delivered in several transport units, visit www.nlpool.no for more information.

Kapittel: 0303	Dok nr: 03 Vers nr: 04	Gyldig fra: 27.08.20	Utarbeidet av: SMSS	Revidert av: SMSS	Godkjent av: FH	Side 3 av 3
----------------	---------------------------	-------------------------	------------------------	----------------------	-----------------	-------------